

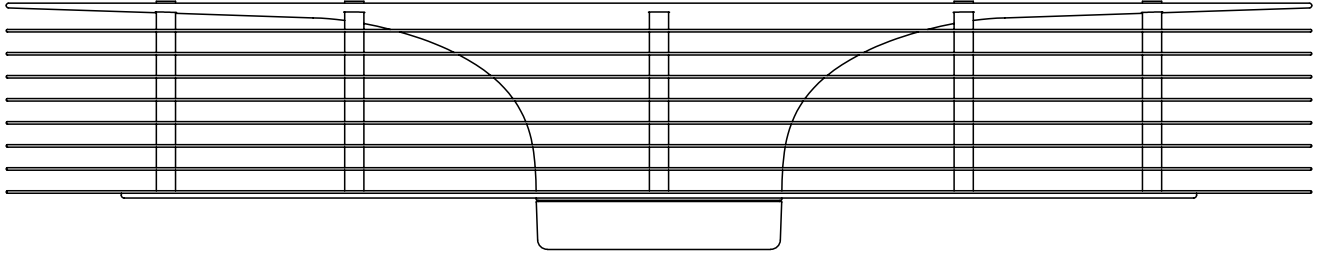

exhale FANS MODEL EF34



Owner's Guide & Installation Manual

 **WARNING:** Read this manual before using this product. Failure to follow the instructions and safety precautions in this manual can result in damage to property, serious bodily injury or death. Keep this manual in a safe location for future reference.

 **WARNING:** This appliance is not to be used by persons (including children) with reduced physical, sensory or mental capabilities, or lack of experience and knowledge, unless they have been given supervision or instruction.



To view the LIMITED WARRANTY for this product, visit www.exhalefans.com.

Model: EF34

Parts List

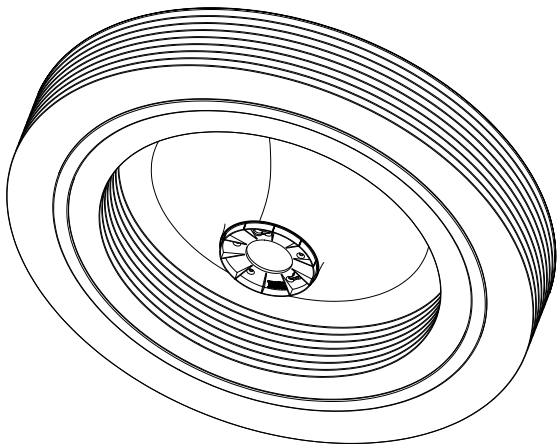

Exhale Fan (Prebuilt)

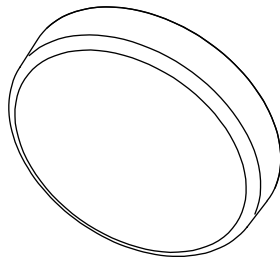

Dust Cover & LED Light

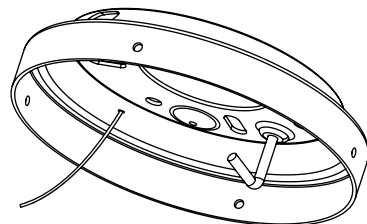

Ceiling Mount

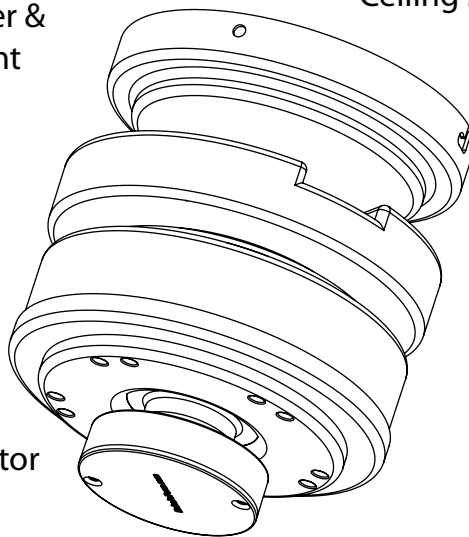

DC Motor

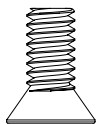

Flat Head Motor Screws (1/4-20)
Qty: 5

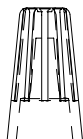
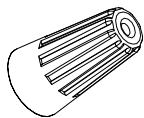

Wire Nuts
Qty: 3

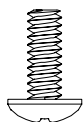

Motor Mount Screws (#10-24)
Qty: 4

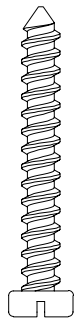

Misc Ceiling Mounting Screws
Qty: 4

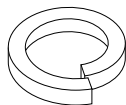

Lock (Vibration) Washers
Qty: 4



Wireless Remote

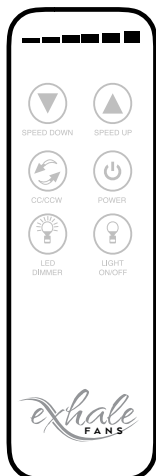

Tools Required

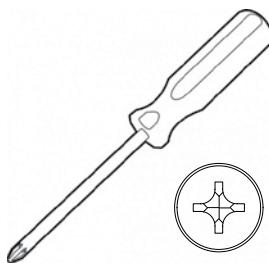

Screw Driver

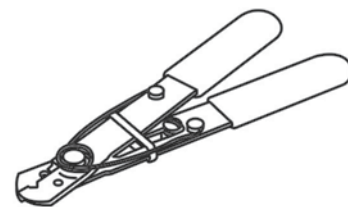



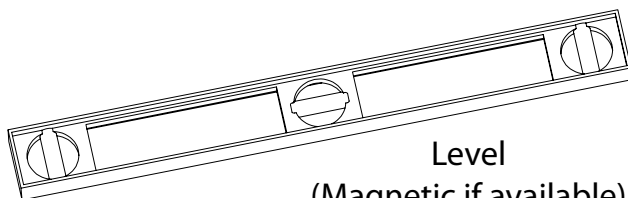



Wire Strippers



Level
(Magnetic if available)

Safety First!

Please read this installation manual completely before you begin to install the Exhale™ Fan. You will be happy you did.

- To reduce the risk of electric shock, ensure electricity has been turned off at the circuit breaker or fuse box before beginning any installation procedures.
- All wiring must be in accordance with local electrical codes. Electrical installation should be performed by a qualified licensed electrician.
-  **WARNING:** To reduce the risk of electrical shock and fire, do not use this fan with any speed control device other than the included wireless remote.
- The outlet box and support structure must be securely mounted and capable of supporting a minimum of 50 pounds. Use only certified outlet boxes marked FOR FAN SUPPORT.
-  **WARNING** To reduce the risk of fire, electrical shock or personal injury, only mount fan to outlet box marked ACCEPTABLE FOR FAN SUPPORT.
- To avoid personal injury or damage to the fan and other items, be cautious when working around or cleaning the fan.
- Do not use water or detergents when cleaning the fan or fan discs. A dry dust cloth or lightly dampened cloth will be suitable for most cleaning.
- After making electrical connections, spliced conductors should be turned upward and pushed carefully into the outlet box.
- Electrical diagrams are for reference only.
-  **WARNING:** To reduce the risk of personal injury, use only the two steel screws (and lock washers) provided with the outlet box for mounting to the outlet box. Most outlet boxes commonly used for lighting fixtures are not acceptable for fan support and may need to be replaced, consult a qualified electrician if in doubt.
-  **WARNING:** This appliance is not to be used by persons (including children) with reduced physical, sensory or mental capabilities, or lack of experience and knowledge, unless they have been given supervision or instruction.
- Children (even supervised) should not play with the appliance.
-  The Exhale Fan should be installed above the floor at a height in accordance with local codes.
- The replacement of parts of the safety suspension system device shall be performed by the manufacturer, its service agent or suitably qualified persons.
- The fixing means for attachment to the ceiling such as hooks or other devices shall be fixed with a sufficient strength to withstand 4 times the weight of the ceiling fan.
- The mounting of the suspension system shall be performed by the manufacturer, its service agent or suitably qualified persons.
- Users are advised to contact the fan supplier to conduct regular examination of the fan suspension system at least once in every two (2) years.
-  All attachments of the fan suspension/ mounting hardware system are provided and designed to be vibration proof. The mounting screws are supplied with Lock/Vibration washers that prevent each attachment point from loosening while the fan is in operation.
-  For installation in the Country of Singapore. The fan and its installation in particular the Suspension/Mounting System shall be Inspected/Examined at least once every two (2) years.

To view the LIMITED WARRANTY for this product, visit www.exhalefans.com.

Model: EF34

Installation

Step 1. Determine the location

The preferred location for the EF34 is in the center of the room, this position will provide the best performance of the fan.

If you intend to place multiple fans in the same room you should divide the room into equal sections and place the fans in the center of each section. In both instances of one or multiple fans, the above recommendations will provide air movement coverage to all corners of the space.

-  **WARNING:** To reduce the risk of fire, electrical shock or personal injury, only mount fan to outlet box marked ACCEPTABLE FOR FAN SUPPORT.

Step 2. Remove contents from the package

The 2-part protective foam covers the entire fan and through the hand hole openings lift the top cover from the box. Located in each corner of the protective foam you will find all the parts located in form fitting slots. Included are the DC motor, mounting hardware, remote, and LED light. Carefully remove each individual part ensuring that all the parts are cross-referenced with the "Parts List" located in the front of this document.

Do not remove the body of the Exhale™ Fan at this time; that will come later in the installation.

Step 3. Turn off all electrical power

Locate your electrical panel or fuse box and turn off the power to the room where you are installing the fan.

-  **WARNING:** Turn off all electrical power prior to making any electrical connections. Failure to do so could result in electrical shock, personal injury, or death.

If you are unsure how to disconnect the electric power, please consult a licensed electrician for assistance.

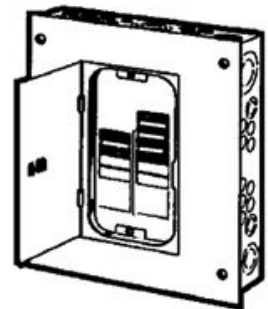

Step 4. Ceiling Mount

- Pass the electrical wires from the ceiling through the ceiling mount center hole as shown in Figure 1.
- Secure the ceiling mount to the junction box *using the hardware supplied with the junction box* as shown in Figure 2.

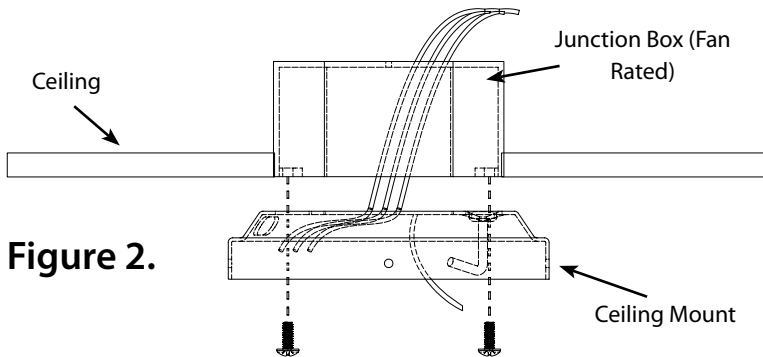

Figure 2.

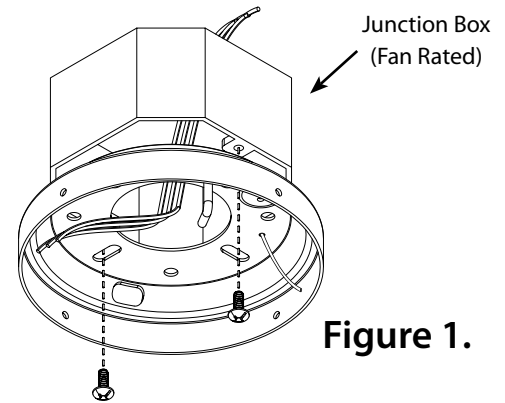

Figure 1.

- Using a level, make sure the mount is plumb and level to the floor, adjust if necessary.

i Installation to concrete ceilings requires optional mounting hardware. (See Optional Accessories A)

i Running the Exhale out of level can cause it to become unstable or wobble.

! **WARNING:** Not using the hardware included with the junction box could result in a weak connection of the ceiling mount to the junction box and cause the fan to become unstable or fall.

Step 5. Electrical Connections

Start by hanging the motor from the ceiling mount hook as shown in Figure 3.

i Note: Your motor may be supplied with wiring colored Red and Black or Black and White. For the Red and Black colored wire pair, the Red wire is Line and the Black wire is Neutral. For the Black and White colored wire pair, the Black wire is Line and the White wire is Neutral.

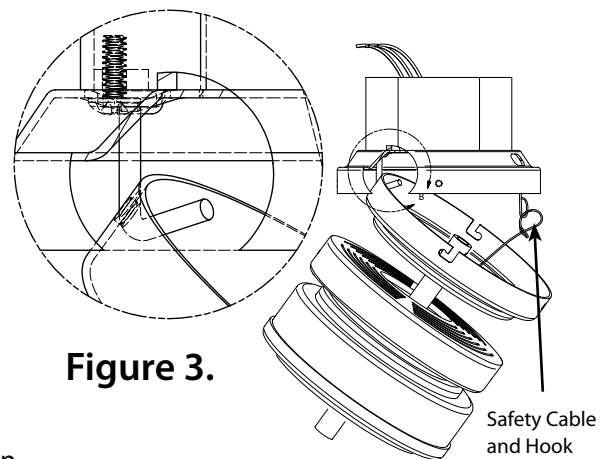
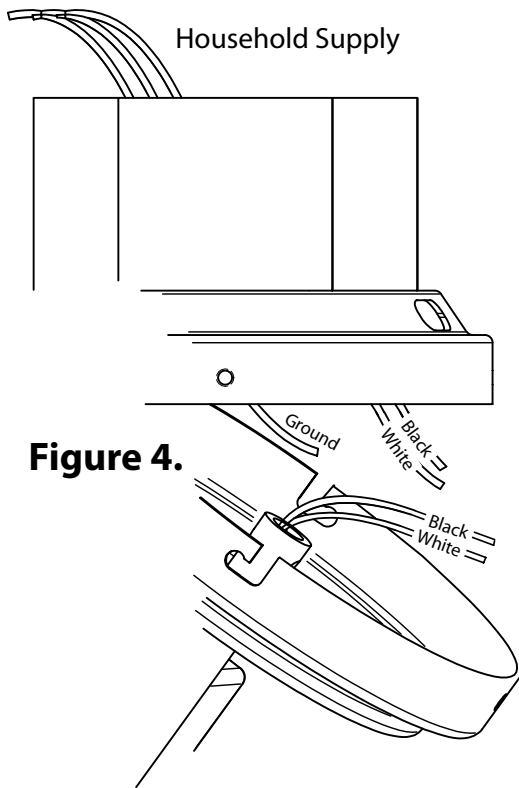

Figure 3.

- Connect the fan supply (Black) wire to the black household supply wire as shown in Figure 4.
- Connect the neutral fan supply (White) to the white household supply as shown in Figure 4.
- Connect the Ground fan wire (Green) to the ground household supply as shown in Figure 4.
- After connecting all the wiring, spread them apart so that the Green and White wires are located on one side of the electrical box and the Black on the other.
- Turn the wire nuts upward and push the wires neatly into the electrical box so they are out of the way.
- Secure the fan safety cable hook through the slot on the ceiling mount that is opposite of the ceiling mount hook.

Model: EF34



WARNING: To reduce the risk of electrical shock, DO NOT use a wall-mounted speed control with this fan. It WILL permanently damage the electronic circuitry.



WARNING: Turn off all electrical power prior to making any electrical connections. Failure to do so could result in electrical shock, personal injury, or death.



Use the wire connecting nuts supplied with your fan. Secure the connectors with electrical tape. Make sure there are no loose strands or connections.



The external earth conductor wire should be longer than both the Line and Neutral wires.

If you are unsure how to disconnect the electric power, or feel that you do not have enough electrical knowledge, please consult a licensed electrician for assistance.

If the installation uses the supplied expansion anchors or the installation is in the Country of Singapore refer to the page in this manual on Concrete Mounting Hardware under Operational Accessories.

Step 6. Mounting the Motor

Pre-install 2 of the included #10-24 screws half-way into the ceiling mount on either side.

Install the motor onto the ceiling mount by sliding the pre-installed bottom mount over the ceiling mount as shown in Figure 5.

Using a clockwise twisting motion, the motor will temporarily lock into the ceiling mount while you install the remaining 2 #10-24 screws and tighten all connections.



Be sure to align the two twist lock channels with the 2 pre-installed screws added first.

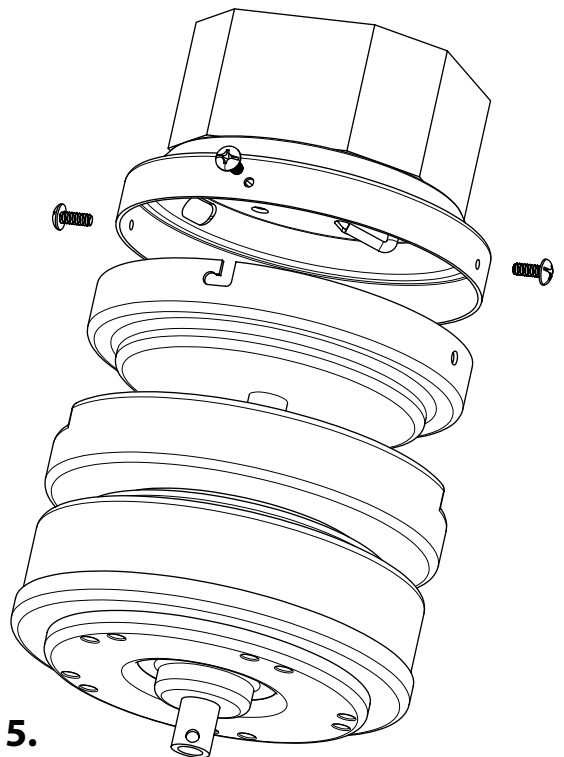

Figure 5.

Step 7. Hanging the Disc Array

- a. Using only (2) of the included 1/4-20 flat head motor mount screws, install them (2) full rotations as shown in Figure 7.



Note: These screws will be tightened completely in a later step.



WARNING: Not installing the screws a full (2) rotations could result in them backing out and causing the disc array to fall prior to installing the remaining screws.

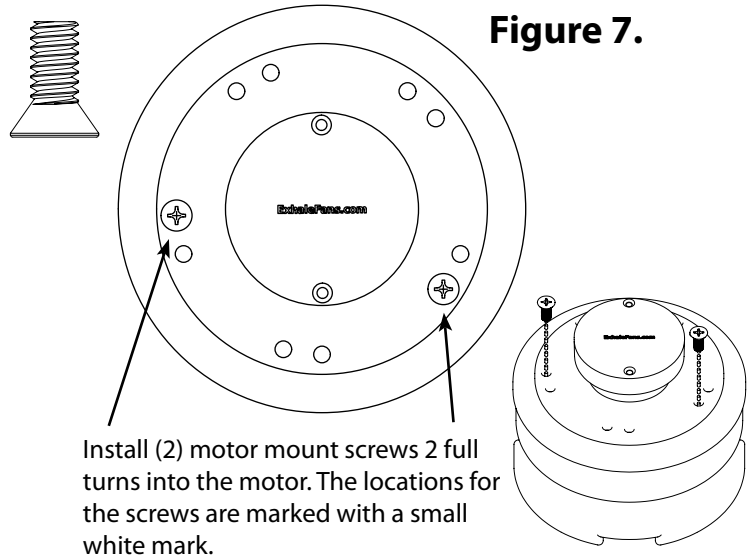
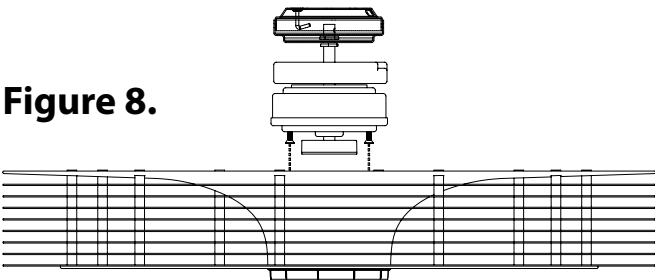

Figure 7.

Install (2) motor mount screws 2 full turns into the motor. The locations for the screws are marked with a small white mark.

Figure 8.



- b. Install the disc array onto the motor by aligning the (2) screws installed earlier to the 'Key Holes' in the disc array as shown in Figure 9.
- c. Rotate the entire disc array counter clockwise to lock the screws into the disc array as shown in Figure 9.



Note: The disc array should be free hanging from the (2) mounting screws.

- d. Install the remaining (3) screws into the disc array tightening all (5) using an alternating pattern to ensure an even pressure is put on all screws.



WARNING: Not tightening the motor mounting screws properly could result in a weak connection of disc array to the motor and cause the fan to become unstable or fall.

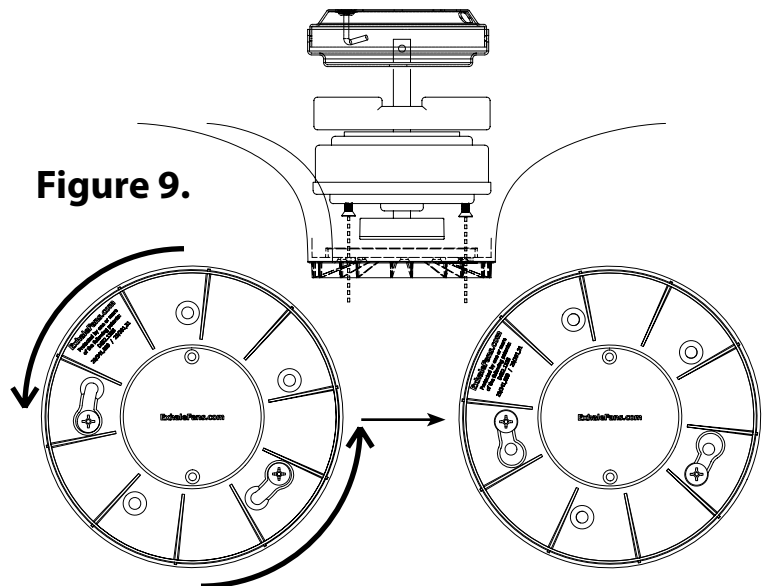

Figure 9.

Model: EF34

Step 8. Install the Dust Cover (Optional LED Lighting system? Skip this step)

Install the dust cover by sliding it over the center of the disc array as shown in Figure 10. The cover is held on by friction and should fit snugly without using extensive force.

Figure 10.

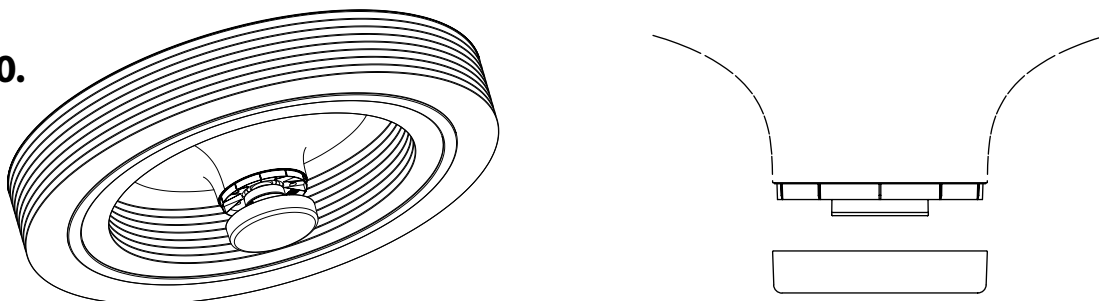

Remote Operation

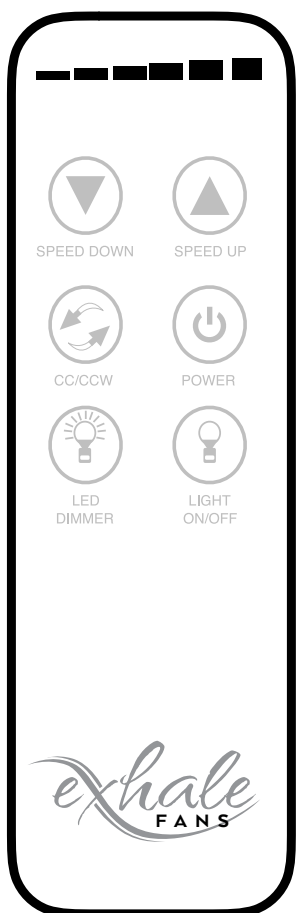

Figure 9a.

BUTTON FUNCTIONS

Upper Left SPEED DOWN

Upper Right SPEED UP

Center Left Clockwise (CW)
Counterclockwise (CCW) rotation

Center Right FAN ON/OFF

Lower Left LED DIMMER

Lower Right LED ON/OFF

Remote Operation (Cont.)



Each remote is pre-programmed to motor when packaged at the factory. However, we have added instructions below on how to program the remote in the event that it may become necessary.

- a. Install the two AAA 1.5 Volt Batteries into the remote transmitter by first removing the battery cover on the back cover. Insert the batteries as indicated with the positive + end of the battery aligned with the + sign on the battery holder.

Operating Functions of the Remote:

The Remote Transmitter has Six Operational Buttons and are depicted (See Figure 9a)

- To turn the fan ON or OFF select the button labeled POWER.
- To Increase or Decrease fan Speed select SPEED UP or SPEED DOWN button. The illuminated scale at the top of the remote will indicate the speed selected, 1 through 6.
 - Please note that the lighted scale on top of the remote will indicate the speed that your fan is operating.
- To change the direction of rotation, Toggle the CW/CCW button for Clockwise direction or Counterclockwise direction. The lighted scale will scroll when the CW/CCW button is depressed, right to left for Clockwise, and Left to right for Counter Clockwise. With your Exhale Fan rotational direction is of personal preference, performance and temperature are not affected.
- Turning on the LED light is made by pressing the LED LIGHT ON/OFF button.
- The LED DIMMER button is used to provide a full-scale dimmer function for your LED. Press and Hold the dimmer button to select the level of illumination that you desire. While holding this button the level of illumination will increase to 100% and then decrease to 20%, just release the button at the level of illumination that you desire.

Remote Programming (Syncing the Remote):

- Turn the power OFF for at least 10 Seconds, if necessary, turn off the Circuit Breaker that routes power to your fan.
- Turn Power to the Fan ON
- Within 60 seconds of turning the power on, press and hold the LED ON/OFF button for 5 seconds. Do not touch any other button during this process, doing so will cause this process to fail.
- Once the Synchronization is completed and detected you will hear an audible "BEEP" which indicates a successful synchronization.
- After completing the steps all fan functions will be available.

Please note that if a Power Failure occurs you may have select the CW / CCW direction button since it is not remembered by the fan.

Model: EF34

Tech Specs



Dimensions

Height:	7.5 in / 18.4 cm
Width:	34 in / 86.4 cm
Weight:	25 lbs / 11.4 Kg



Voltage Options

AC Input 100 – 265 Volts,
50 or 60 Hz.



Energy Usage

Level 1:	4 Watts, 120 RPM
Level 2:	6 Watts, 158 RPM
Level 3:	9 Watts, 198 RPM
Level 4:	16 Watts, 236 RPM
Level 5:	36 Watts, 274 RPM
Level 6:	50 Watts, 285 RPM



Sound dB

Level 1:	33-35 dB
Level 2:	35-37 dB
Level 3:	36-38 dB
Level 4:	37-38 dB
Level 5:	38-41 dB
Level 6:	40-45 dB

(40 dB = Quiet Library)



Optional LED Lighting System

Watts:	15 at 100%
Dimmable:	20% to 100%
Lumens:	850-1050 at 100%

Cool White:	5500K
Warm White:	4000K

Cleaning and Maintenance

With any fan, dust will collect on the leading edges where the air passes over.

Using a damp cloth with a mild detergent, wipe the dust from the interior and exterior edges of the discs.

Alternatively, you can use the brush attachment of your vacuum cleaner to remove dust collected on the interior and exterior surfaces of the fan.

We recommend cleaning the fan once a month to keep dust to a minimum and keep your fan running at its optimum.

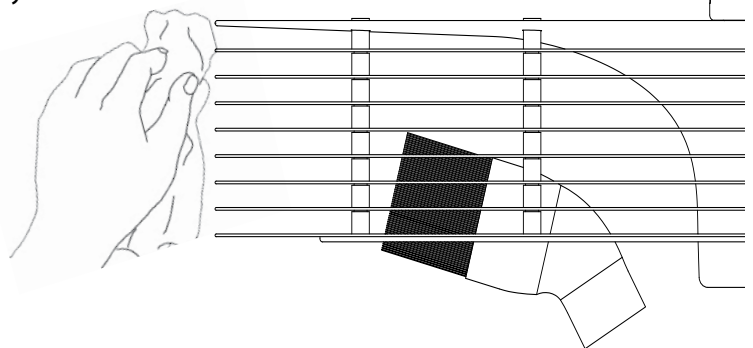

WARNING: Make sure the fan is turned off and is not spinning before attempting to clean with either of the methods listed above.

Optional Accessories

A. Concrete Mounting Hardware

Concrete mounting hardware **MUST** be used when installing directly to concrete without the use of a junction box.

i Installation step 1-3 should be completed prior to installation of the ceiling mount.

- a. Place the ceiling mount flush onto the ceiling in the location where the fan will be mounted.
- b. Using the mount as a guide, mark the 5 bolt locations onto the ceiling where the expansion anchors will be installed.

Parts List

Expansion Anchors

Non Hook
Qty: 3

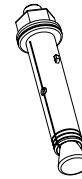

Hook Anchor
Qty: 1

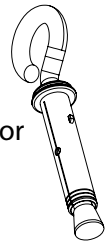

- c. Remove the ceiling mount from the ceiling and check that the 5 locations marked are clear and free from obstacles. *(Note: Use one of the slotted holes in the mount for the anchor with the hook attachment)*
- d. Using a 10mm drill bit, drill the 4 bolt locations at least 40mm deep into the concrete ceiling. *(Be sure to clean any remaining dust from the hole when finished.)*
- e. Run the supply wires through the center of the ceiling mount and secure the mount to the ceiling using the included 4 expansion anchors.

Figure A.

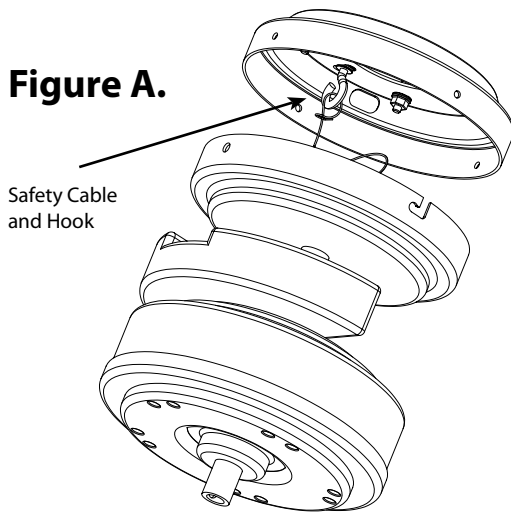

- f. [Refer to Installation Step 5. Electrical Connections]
- g. Secure the fan safety cable to the Hook Expansion Anchor by placing the open loop of the safety cable over the hook, as seen in Figure A. The safety cable provided is a backup to the main suspension / mounting system. One end of the Safety Cable is anchored to the fan with the opposite end being free to pass through a "down Rod" thus fixing the free end of the cable securely to the building structure from which the fan is suspended / mounted. The safety cable is thus to be attached to the Hook Expansion Anchor.
- h. [Return to Installation Step 6. Mounting the Motor]

Model: EF34

Optional Accessories (Continued)

C. LED Lighting System

 **WARNING:** Turn off all electrical power prior to making any electrical connections. Failure to do so could result in electrical shock, personal injury, or death.

Parts List

Main Housing

LED Housing

Spacers

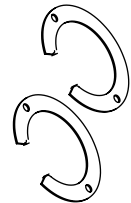
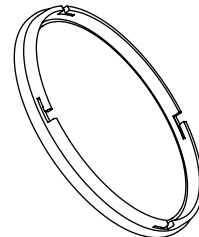
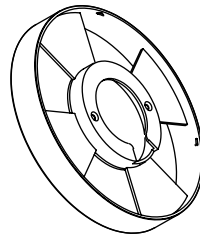

- Turn off all electrical power to the fan while making any electrical connections.
- Once the disc array has been installed, leveled, and you are happy with its operation, remove the cover from the housing located directly below the fan, shown in Figure A.

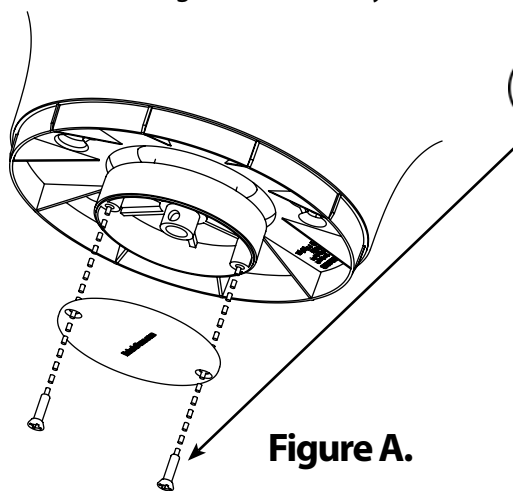

Figure A.



Retain the 2 mounting screws removed from the lower housing, they will be used later.

- Mount the Main LED Housing to the lower housing using the 2 screws retained from the last step, shown in Figure B.
Note: You may need to use one or more of the included spacers between the lower housing and Main LED Housing to achieve clearance between the fan and the LED lighting system to ensure smooth operation without rubbing.



Please take the time to make sure the fan rotates freely with the Main LED Housing

- Make the appropriate electrical connection from the LED Housing to the motor.
Note: The connectors used from the motor to the LED Housing are Male/Female and can only be installed one way!
- Take care to tuck the wires into the lower housing using the Main Housing's cutaway as a channel to run the wires.
- You can now line up the tangs of the Main Housing to the retainer clips from the LED Housing and gently rotate clockwise to lock them in place.

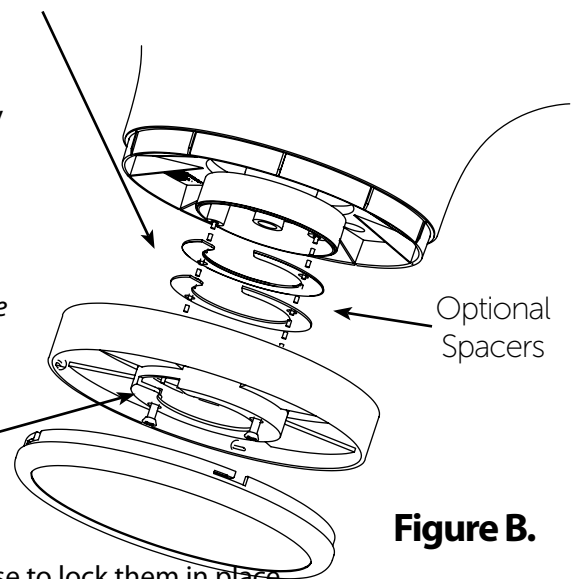

Figure B.